

MECHANICAL ENGINEERING-ME



GATE / PSUs

STUDY MATERIAL

MANUFACTURING ENGINEERING



eii ENGINEERS
INSTITUTE OF INDIA



MECHANICAL ENGINEERING

GATE & PSUs

STUDY MATERIAL

MANUFACTURING ENGINEERING

CONTENT

1.	WELDING	3-38
2.	CASTING (FOUNDING)	39-82
3.	METROLOGY & INTERFEROMETRY	83-105
4.	UNCONVENTIONAL MACHINING	106-130
5.	METAL CUTTING	131-169
6.	METAL CUTTING-II.....	170-214
7.	GEAR MANUFACTURING.....	215-227
8.	JIGS AND FIXTURES	228-240
9.	METAL FORMING.....	241-282
10.	NUMERICAL CONTROL	283-300

CHAPTER-1

WELDING

Welding is a fabrication process that joins materials, usually metals/thermoplastics, by causing coalescence. This is commonly done by melting the work pieces and adding a filler material to form a pool of molten material that cools to become a strong joint, with pressure sometimes used in conjunction with heat, or by itself, to make the weld. This is in contrast with soldering and brazing, which include melting a lower-melting-point material between the work pieces to form a bond between them, without melting the work pieces.

Various energy sources can be used for welding, including an electric arc, a gas flame, a laser, an electron beam, friction, and ultrasound. While often an industrial process, welding may be performed in several environments, including open air, under water and in outer space.

Products obtained by the process of welding are called “weldments”.

Classification of joining process:

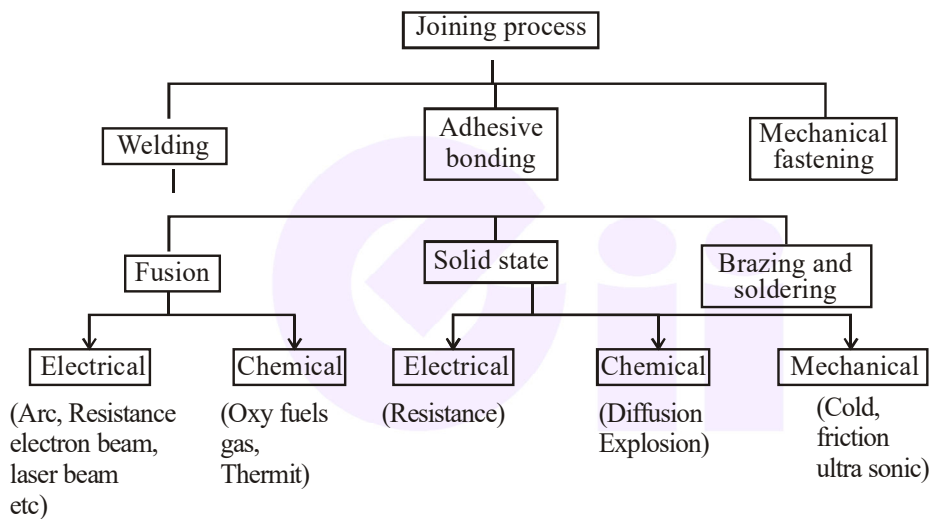

Welding process can be divided into three basic categories

(i) fusion welding

(ii) solid state welding

(iii) brazing and soldering.

- **Fusion welding:** It is defined as the melting together and coalescing of materials by means of heat (Commonly supplied by electrical or chemical means); filler metals may or may not be used. It consists of consumable or non-consumable electrodes arc welding and high-energy-beam welding processes.
- **Solid state welding** takes place in the absence of fusion; consequently there is no liquid phase in joint. The main categories are diffusion bonding and cold, ultrasonic, friction, resistance, and explosion welding. Diffusion bonding, combined with super plastic forming, has become a major manufacturing process for complex shapes.
- **Brazing and soldering** utilize filler metals and involve lower temperatures than welding; the heat required is supplied externally.

Adhesive bonding has been developed into an important technology due to its several advantages; it has peculiar applications requiring strength, sealing, insulating, vibration damping, and resistance to corrosion between different metals. Included in this category are electrically-conducting adhesives for surface-mount technologies.

- **Mechanical fastening** consists of traditional methods of using several fasteners, bolts, nuts, & rivets.
- **Joining plastics** can be carried out by adhesive bonding, fusion by various external or internal heat sources, & mechanical fastening.

The selection of a joining process depends on many factors: (1) the application, (2) the joint design, (3) the materials involved; (4) the shapes of the components to be joined, their thickness, & their sizes

Fusion-Welding processes

(A) Oxyfuel Gas Welding (OFW): It is a general term used to describe any welding process that uses a fuel gas mixed with oxygen to produce flame. This flame is the source of the heat that is applied to melt the metals at the joint.

The most common gas-welding method uses acetylene fuel; it is called as **oxyacetylene (OAW) Welding** and is applied typically for structural sheet metal fabrication.

- This process uses the heat generated by the combustion of acetylene gas (C_2H_2) in a mixture with oxygen (O_2).

The heat is produced in accordance with a pair of chemical reaction.

Primary combustion process $C_2H_2 + O_2 \longrightarrow 2CO + H_2 + \text{Heat}$

It generates $\frac{1}{3}$ rd of the total heat produced in the flame.

Secondary combustion process $2CO + H_2 + 1.5O_2 \longrightarrow 2CO_2 + H_2O + \text{Heat}$

This 2nd reaction generates about $\frac{2}{3}$ rd of total heat. The temperature created in the flame as a result of these reaction can reach 3300°C.

Types of flames: The proportions of acetylene and oxygen in the gas mixture are major factor in oxyfuel gas welding. On proportions basis three type of flames.

1. Neutral flame: At the ratio of 1:1, that is when there is no excess oxygen, it is considered to be a natural



flame.

The reducing and neutral flames are useful in soldering and annealing.

2. Oxidizing flame: It is the flame produced with an excessive amount of oxygen. With a greater oxygen provide, natural flame becomes an oxidizing flame.

- This flame is injurious especially for steels, because it oxidizes the steel.
- Only in the welding of copper and copper alloys is an oxidizing flame desirable, because in those circumstances a thin protective layer of slag forms over the molten metal.

3. Reducing or carburizing flame: It is the flame with low oxygen. It has a yellow or yellowish color because of carbon or hydrocarbons. The reducing flame is also known as the carburizing flame, since it tends to introduce carbon into the molten metal.

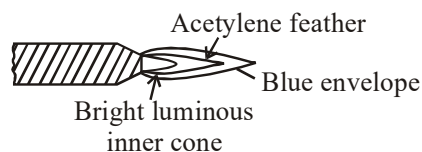

- The temperature of carburizing flame (one having excess acetylene) is lower, so it is appropriate for applications requiring low heat namely brazing, soldering & flame-hardening.

Flame	Natural flame	Oxizing flame	Carburizing flame
Temp(°C)	≈ 2900° C	≈ 3280° C	≈ 3100° C

Filler metals: A **filler metal** is a metal supplied in the making of a joint through welding, brazing, or soldering. Four types of filler metals exist: **(1)** covered electrodes **(2)** bare electrode wire or rod **(3)** tubular electrode wire **(4)** welding fluxes. At times non-consumable electrodes are included as well, but since these metals are not consumed by the welding process, they are normally rejected.

Covered electrodes:

These are used extensively in shielded metal arc welding

Bare electrode wires:

It used in gas metal arc welding and bare electrode rods are used in gas tungsten arc welding.

Tubular electrode wires:

It is used in flux-cored arc welding.

Welding fluxes:

Welding fluxes are used in submerged arc welding.

Flux : It retards oxidation of the surfaces of the parts being welded, by generating a gaseous shield around the weld zone.

- It also help to dissolve and remove oxides and other substances from the work piece and so contributes to the formation of a hardy joint.

Equipment: A oxy-acetylene welding outfit incorporates the supply units for oxygen and acetylene with associated regulator & the torch which mixes the two gases before they are ignited.

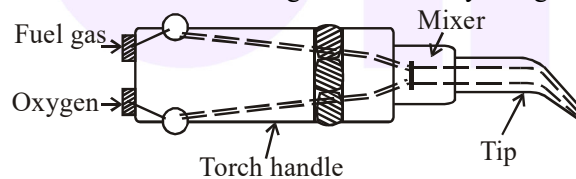

- The oxygen is commonly stored in strong cylinders at a pressure ranging from 13.8 MPa to 18.2 MPa.
- Acetylene is normally made available in the following two forms:
 - (1) Acetylene storage cylinder
 - (2) Acetylene generator.

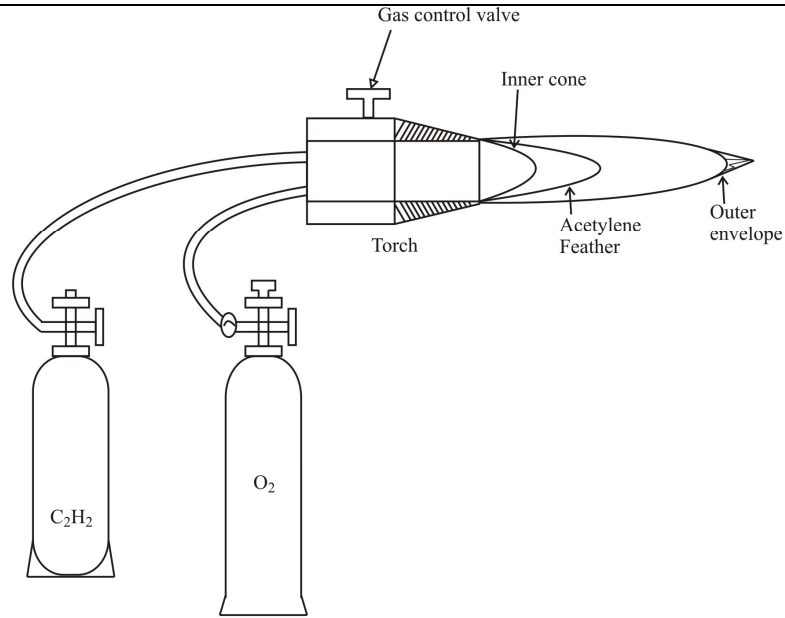

GAS WELDING

Free acetylene is highly explosive if stored at a pressure greater than 200 kPa, where it becomes very unstable and likely to explode. Therefore acetylene need to be carefully stored cylinder filled with 80 to 85% porous, material such as calcium silicate & then filled with acetone which can absorb up to 420 times its volumes of acetylene at a pressure of 1.75 MPa. It is expected that the acetylene molecules fit in between the acetone molecules.

It is as well possible to have an acetylene generator in the place of acetylene cylinder. Acetylene is normally produced by a reaction between calcium carbide & water which is instantaneous as shown

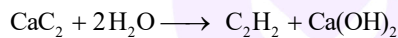

Joining process – Oxyfuel	Advantage – Portable and flexible
Operation – Manual	Skill level – High
Welding position – All	required
Current type – No	Distortion – 2 to 4*
Cost of equipment – Low	*1 – highest 5 – Lowest

Pressure gas welding: This method of welding two components starts with the heating of the interface by means of torch using, typically oxyacetylene gas as shown in fig.

After interface begins to melt, the torch is withdrawn, and a force is applied to press the two components together. The force is maintained until the interface solidifies. Note the formation of a flash due to the upsetting of the joined ends of the two components.

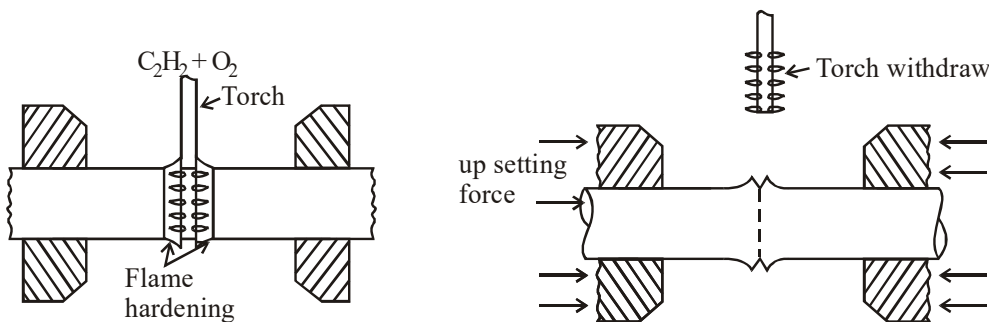

Fig: Schematic illustration of the pressure-gas welding process.

(B) ARC-WELDING PROCESSES:

It is a type of welding that uses a welding power supply to create an electric arc between an electrode and the base material to melt the metals at the welding point. They can utilize either direct (DC) or alternating (AC) current, and consumable or non-consumable electrodes. The welding zone is normally protected by some type of shielding gas, vapor, or slag. This processes may be manual, semi-automatic, or fully automated.

Principle of Arc:

- An arc is generated between two conductors of electricity cathode and anode (considering direct current, DC), when they are touched to set up the flow of current and then separated by a small distance.
- An arc is a sustained electric discharge through the ionized gas column, known as plasma, between the two electrodes.
- It is commonly believed that electrons liberated from the cathode move towards the anode and are accelerated in their movement. When they strike the anode at large velocity higher amount of heat is created.
- When the electrons are moving through the air gap between the electrodes, also called the arc column, they collide accompanied by the ions in the ionized gas column between the electrodes.
- About 65 to 75% of the total heat is released at the anode by the striking electrons. A temperature of the order of 6000°C is produced at the anode.
- In order to create the arc, the potential difference between the two electrodes (voltage) should be enough to allow them to move across the air gap. The larger air gap needs higher potential differences. If the air gap becomes too large for the voltage, the arc may be destroyed.
- In case of an Arc, the excess energy spent crossing the air gap is liberated as heat.
- An arc of the alternating current (AC), it would be similar with the main difference that the cathode & anode would change endlessly and as a result, the temperature across the arc would be more uniform compared to a direct current (DC) arc.

Arc-welding equipment: The major requirement in an arc-welding set-up is the source of electric power. They are two types:

(a) Alternating current (AC) machine

- (i) Transformer (ii) Motor or engine-driven alternator.

(b) Direct current (DC) machine

- (i) Transformer with DC rectifier (ii) Motor or engine-driven generator.

The transformer does not have any moving part and as a result operates with little maintenance cost & also has higher efficiency. In AC machine, generally only transformers are used.

In DC arc-welding, a rectifier or a generator can be utilized to supply the required DC power. In the rectifier type, the power supply is 1st stepped down by means of a transformer to the required voltage & then silicon controlled rectifiers (SCR) are applied to convert AC to DC. These rectifiers are very compact highly reliable and have higher efficiency.

The welding machines can be divided into two types, based on the characteristics.

1. Constant: Current welding machines or droop curve machines or simply droopers.

2. Constant: Voltage arc-welding machines.

1. Constant current welding machine: This machine varies the welding voltage to account for the change in the arc gap, therefore maintaining the arc current. As a result of this, the characteristics of the machine (a plot between output voltage (volts) and output current (Amperes) is a drooping one, as shown in figure.

It indicates the setting of open-circuit voltage (no welding) at 80 volts. It can be seen that for huge change in output voltage the corresponding alter in current is so small that the quality of the weld can be maintained.

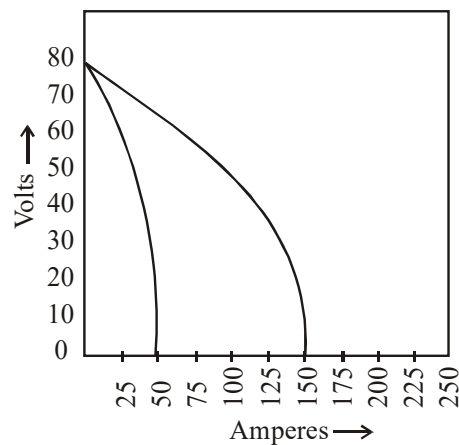

This is very necessary for manual arc-welding processes since the maintenance of constant arc is nearly not possible by a human welder.

2. Constant voltage arc-welding machine: This machine has a more flat characteristic curve (fig). The slope of curve is much flat that any small change in voltage makes for an highly change in the output currents.

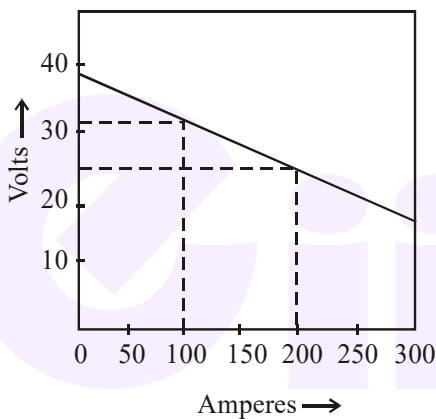

These systems are normally preferred in automatic machines since they becomes self-corrective.

e.g., when the electrode comes a bit closer to the work, the arc voltage drops, raising the output current to a very large value. This current instantly, melts the electrode and thus maintains the arc gap.

Comparison between DC and AC arc-welding: Though DC arc welding is more expensive than AC welding, it is commonly preferred because of the control of heat input offered by it.

As about 70% of heat is released near the anode (+) in DC arc-welding, so if more heat is necessitated at the work piece side, such as for thicker sheets of for the materials which have larger thermal conductivity such as aluminum and copper, the work can be made as the anode (positive), liberating large heat neat it. This is named as straight polarity or DCEN (Direct Current Electrode Negative). This gives rise to a higher penetration.

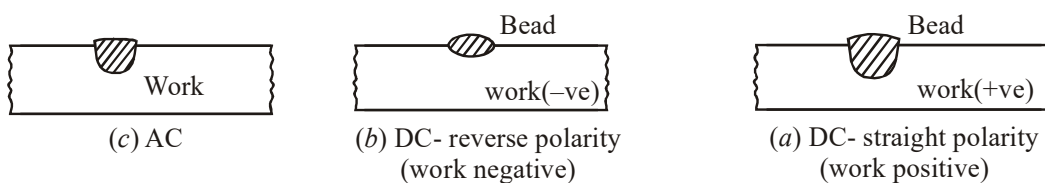

For thinner materials, where less heat is needed in the weld zone, the polarity could be reversed by making the work -ve. This is called reversed polarity or DCEP (Direct current electrode positive). In reversed polarity, the penetration is small.

In AC welding, the bead obtained is some where in between the OCEN & DCEP.

Specification of arc-welding machines:

1. Maximum rated open-circuit voltage: It is the voltage between the output terminal when no welding is being done, is generally fixed at about 80V. This is the maximum and normally, a voltage of the order of 40 to 50 V should be enough for starting an arc, while on the contrary for continuous welding, 20 to 30V is enough. The minimum welding load voltage V_m can be determined as

$$V_m = 20 + 0.04I$$

I = Load current in amperes.

2. Rated current in amperes: It is the maximum current in amperes (A) that a welding machine is capable of providing at a given voltage. The preferred current as per BIS : 1851 – 1966, are 150, 200, 300, 400, 500, 600 and 900 A.

3. The duty cycle: It is described by American welding society (AWS) is “The percentage of time in a 10 minute period that a welding machine can be utilized at its rated output without overloading”.

Generally a 60% duty cycle is suggested. The Indian standard specifies 5 min as the cycle time and thus for every 5 min of welding transformer operation, 3 min is for welding and 2 min is for no load operation. But continuous, automatic welding machines may need the welding machine to manage at 100% duty cycle.

The actual duty cycle can be determined as follows:

$$\text{Required duty cycle} = T_a = \left(\frac{I}{I_a} \right)^2 T$$

Where, T = Rated duty cycle

I = Rated current at the rated duty cycle.

I_a = Maximum current at the rated duty cycle.

Electrodes: In arc welding an electrode is utilized to conduct current through a workpiece to fuse two pieces together. Relying on the process, the electrode is either consumable, in the case of gas metal arc welding or shielded metal arc welding, or non-consumable, i.e., in gas tungsten arc welding.

For a direct current (DC) system the weld rod or stick may be a cathode for a filling type weld or an anode for other welding processes. For an alternating current (AC) arc welder the welding electrode would not be considered an anode or cathode.

Consumable electrodes: When the arc is achieved with a consumable electrode, the weld metal under the arc melts, as also the tip of the electrode. The metal molt from the electrode and base metal intimately mixed under the arc and provides the essential joint after solidification.

- Since the electrode continuously melts, it also acts as the filler rod to supply the filler metal into the joint. Hence the function of providing a filler metal and heat are both built into a single electrode.
- When consumable electrodes are utilized, the welding process is known as metal arc welding.
- A consumable electrode applied in welding can be either bare or coated. The coated electrode, also called stick electrode is useful for manual arc welding method.

Coated electrode advantages:

1. The coatings give off inert gases such as carbon dioxide under the arc heat, which shields the molten metal pool and protects it from the atmospheric oxygen, hydrogen and nitrogen pick-up, therefore reducing contamination of the weld metal.
2. It supplies flux to molten metal pool, which mixed with the oxides and other impurities present in the puddle, form a slag. The slag being lighter, floats on the top of the puddle and shield it against the surrounding air during the weld-bead solidification.
3. Some elements that are needed for stabilization of the arc also added in these coatings.

4. Significant alloying elements can be established through these coatings to enhance the strength and physical properties of the weld metal.

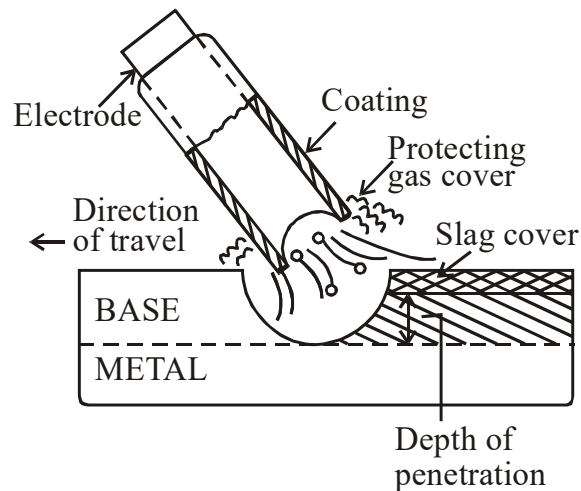

Disadvantage: One of the main concerns with the coated electrode is the moisture pick-up by the coating. This moisture, when it goes into the puddle, dissociates into oxygen and hydrogen with the hydrogen being absorbed by the liquid metal and subsequently liberated during solidification, causing porosity. Hence, it is preferable that electrodes are kept in oven to keep them thoroughly dry.

Non-consumable electrodes: These are made of carbon, graphite or tungsten.

- The carbon and graphite electrodes are utilized only in DC welding, on the other hand tungsten electrodes are applied for both AC and DC.
- The filler metal required has to be deposited through a separate filler rod.

Hence, in this welding process it is possible to properly control the heat input as well as the amount of filler metal deposited, since the two are separately controlled.

When non-consumable electrodes are utilized, they are named by the electrode material used. e.g., carbon-arc welding or tungsten arc welding.

Arc-welding processes (Consumable electrode)

1. Manual metal-arc welding or shielded metal-arc welding (SMAW) or stick or covered welding:

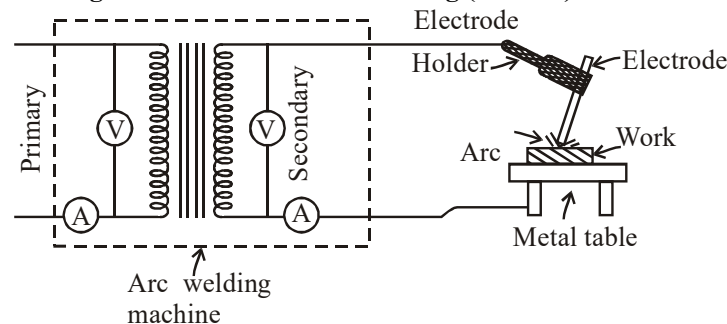

This process is highly versatile and can be used extensively for both simple as well as sophisticated jobs.

In this method the work piece machine is kept on a metallic table to which the ground lead of the secondary welding transformer is attached. The other end of the secondary is attached to an electrode holder into which the electrode is gripped. When the electrode is brought into touch with the work, welding takes places.

- A job of any thickness can be welded by this process (SMAW). But very small thickness below 3 mm may give rise to difficulties in welding due to their lack of rigidity. By the same token, very large thickness above 20 mm may take a large time for filling up the joint groove.
- The SMAW can be done with either an AC or DC power source. The typical range of the current uses may vary from 50 to 500 A with voltage from 20 to 40V.

➤ The electrode for welding operation should be chosen properly, relying on the requirements of the welding. The major points to be considered are the following:

- (1) Composition of the base metal, which finds the electrode composition.
- (2) Tensile strength of the required joint.
- (3) Thickness of the base metal for thinner metals the current setting should be less.
- (4) Required metal-deposition rate.
- (5) Type of arc welding equipment applied DC arc welding equipment is preferable for over head welding.
- (6) Weld position-flat, horizontal, vertical or overhead.

Disadvantage:

- (1) SMAW is the slow speed. Weld metal deposition rates may be in the range of 1 to 8 kg/h in flat position.
- (2) There are much chances of slag inclusion in bead.
- (iii) Moisture pick-up for electrode is required to reduce.

Submerged arc welding (SAW): is a common arc welding method. It needs a non-continuously fed consumable solid or tubular (flux cored) electrode. The molten weld and the arc zone are shielded from atmospheric contamination by being "submerged" below a blanket of granular fusible flux including of lime, silica, manganese oxide, calcium fluoride, and other compounds as shown in fig. When molten, the flux becomes conductive, and supplies a current path between the electrode and the work. This thick layer of flux totally covers the molten metal and hence stopping spatter and sparks as well as suppressing the intense ultraviolet radiation and fumes that are a part of the shielded metal arc welding (SMAW) method.

SAW is generally operated in the automatic or mechanized mode, though, semi-automatic (hand-held) SAW guns with pressurized or gravity flux feed delivery are applicable. The process is usually limited to the flat or horizontal-fillet welding positions. Deposition rates approaching 100 lb/h (45 kg/h) have been reported. Although Currents ranging from 300 to 2000 A are generally utilized, currents of up to 5000 A have also been used in multiple arcs.

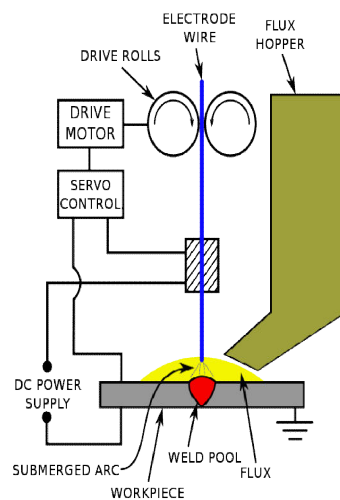

Fig: Submerged Arc Welding (SAW)

SAW process variables:

- Arc voltage
- Wire feed speed (main factor in welding current control)
- Travel speed
- Electrode stick-out (ESO)
- Polarity and current type (AC or DC) and variable balance AC current

Advantages:

- High deposition rates.
- High operating factors in mechanized applications.
- Sound welds are readily made.
- Deep weld penetration.
- High speed welding of thin sheet steels up to 5 m/min (16 ft/min) is feasible.
- Minimal welding fume or arc light is emitted.
- Less distortion
- Practically no edge preparation is require.
- This method is appropriate for both indoor and outdoor works.
- Welds manufactured are sound, uniform, ductile, corrosion resistant and have good impact value.
- 1le pass welds can be made in thick plates with normal equipment.
- The arc is always covered below a blanket of flux, hence there is no chance of spatter of weld.
- 50% to 90% of the flux is recoverable.

Limitation:

- Limited to ferrous (stainless steels or steel) and some nickel-based alloys.
- Normally limited to the 1F, 1G, and 2F positions.
- Normally limited to long straight seams or rotated pipes or vessels.
- Requires relatively troublesome flux handling systems.
- Flux & slag residue can present a health and safety concern.
- Requires inter-pass and post weld slag removal.

3. Gas metal-arc welding (GMAW) or metal inert gas (MIG) welding: In GMAW or MIG welding the consumable electrode is in the form of a wire reel, which is fed at a constant rate through the feed rollers. The welding torch is attached to the gas supply cylinder, which provided the essential inert gas. The power supply is always of **constant voltage** type only. The electrode and work piece are connected to the welding power supply. The current from the welding machine is varied by the rate of feeding of the electrode wire. Generally, DC arc-welding machines are utilized for GMAW with electrode positive (DCEP). The DCEP strengthen the metal deposition rate and also provides for a stable arc and smooth electrode metal transfer. With DCEN, the arc becomes highly unstable and also result in a large spatter. But particular electrodes having calcium and titanium oxide mixture as coating are found to be fine for welding steel with DCEN.

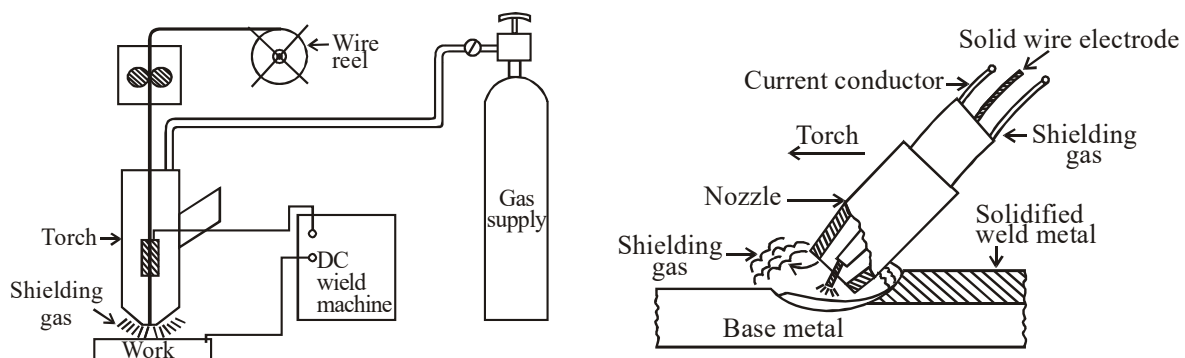

Metal transfer: In GMAW filler metal transferred from the electrode to the joint. Depending on the current and voltage used for a given electrode, the metal transfer is done in different ways. They are

1. Short circuit or dip transfer
2. Globular transfer
3. Spray transfer etc

Shielding gases: Argon, helium and some time CO_2 (carbon dioxide) used.

4. Pulse spray transfer: By the reason of larger heat input and deep penetration, spray transfer is not suitable for thin materials. For such utilization pulsed spray transfer is normally applied. It is similar to spray transfer except that the current required for melting the electrode tip is given in regular pulse rather than continuously.

5. Rotating spray transfer: As the welding current is increased beyond what is required for the spray transfer, rotating spray transfer results.

In this, the end of the electrode wire melts and rotates in a spiraling or helical pattern. Due to this rotation, the weld pool is extended over a large area, resulting in poor penetration. This process is useful for depositing a large amount of metal.

Shielding gases: The gases that can be utilized in GMAW are argon, helium, nitrogen, oxygen, carbon dioxide and a mixture of the above gases in various proportions

Argon:

- (1) Reduces the spatter and concentrates the arc.
- (2) It gives deep penetration welds.
- (3) It ionizes easily, requiring smaller arc voltage.
- (4) It has lower thermal conductivity and therefore conducts heat very slowly from the arc to the weld zone.
- (5) It is good for welding thin sheets.

Helium:

- (1) It has a better thermal conductivity.
- (2) It is good for welding thick sheets.
- (3) The filler metal-deposition rate by helium is much higher compared to argon because of the higher current-carrying capacity.

Carbon dioxide:

- (1) Arc in CO_2 is unstable and therefore a very short arc is to be used to reduce metal spatter.
- (2) It is heavy gas and therefore covers the weld zone very well.
- (3) The metal transfer is only globular with the carbon dioxide.

Non-Consumable Arc-welding process:

1. Gas tungsten arc welding (GTAW) or Tungsten inert-gas. (TIG) Welding: TIG or GTAW process using non-consumable electrode.

The electrode may also contain 1 to 2% thorium (thorium oxide) mixed along with the core tungsten or tungsten with 0.15 to 0.40% zirconia (zirconium oxide).

- > Pure tungsten electrodes carry less current.
- > The thoriated tungsten electrodes carry high current and are more desirable because they can strike and maintain a stable arc with relative ease.

On overall performance basis:

Pure tungsten > Zirconia added < Thoriated

Operation: It includes of a welding torch at the centre of which is the tungsten electrode. The inert gas is supplied to the welding zone through the annular path surrounding the tungsten electrode to effectively displace the atmosphere around the weld puddle. The smaller weld torches may not be provided with any cooling devices for the electrodes, but larger ones are supplied with circulating cooling water.

Published Books

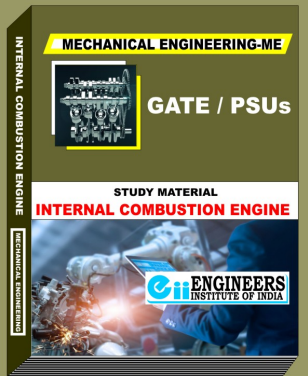
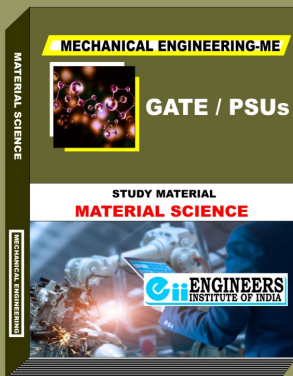
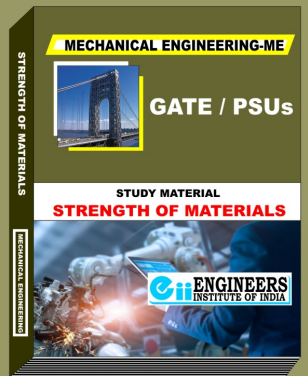
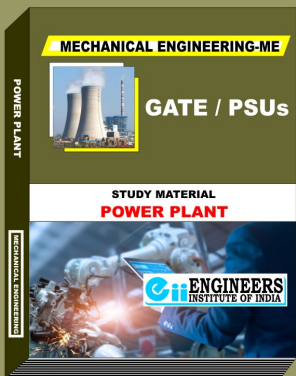
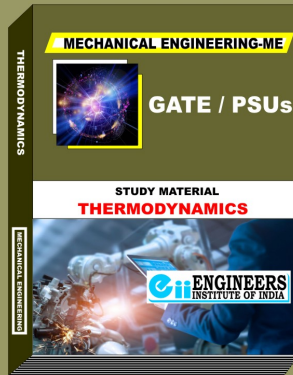

Classroom Batches

Online Classes

Postal Course Classes

Online Test Series

Office: 58B, Kalu Sarai Near Hauz Khas Metro Station New Delhi-16

Helpline: 9990657855 , 9990357855

www.engineersinstitute.com